

Dostek DNC

Getting Started Guide

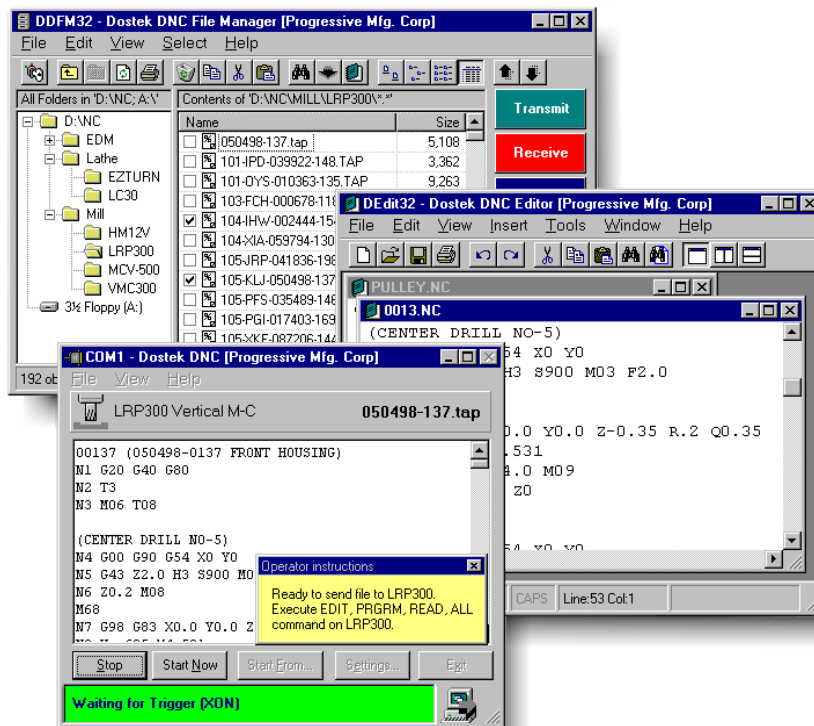

DOSTEK

Dostek Incorporated
238 Westheights Drive
Kitchener, Ontario
Canada N2N 1J9
Tel (519) 742-5721
Fax (519) 741-8669
www.dostek.com

Trademark

"Dostek DNC/32" is a trademark of Dostek Incorporated.

Copyright

© Copyright 1998-2002, Dostek Incorporated.
All rights reserved.

No part of this Document may be reproduced in any form or by any means without prior written consent of Dostek Incorporated, except when for the exclusive use of the licensee and in accordance with the "Software License Agreement" below.

END-USER SOFTWARE LICENSE AGREEMENT - Dostek DNC/32™

This Dostek End-User License Agreement is a legal agreement between you (an individual or legal entity) and Dostek Incorporated for the Software Product know as "Dostek DNC/32". The Software Product includes the computer software and data files, and the printed and on-line documentation. By installing or using the Software Product, you agree to the terms of this agreement. If you do not agree to the terms of this agreement, you may return the Software Product for a refund within 30 days of purchase.

COPYRIGHT

All title and copyrights in and to all components of this Software Product (and all copies thereof) and the accompanying printed materials are owned by Dostek Incorporated. This Software Product is protected by United States, Canadian and international copyright laws and treaties. You may make an unlimited number of copies of the software, provided that such copies are used only for internal purposes in compliance with the terms of this License Agreement and provided that such copies are not republished or distributed to any third party. You may make an unlimited number of copies of the printed or on-line documentation, provided that such copies are used only for internal purposes and are not republished or distributed to any third party.

SOFTWARE PRODUCT LICENSE

This Software Product is licensed (not sold). This License Agreement grants you the following rights:

1. Use of Software Product. Dostek grants you a non-exclusive license to install copies of the Software on any number of computers provided that the Software may be used on only one computer at any time for each license purchased. A license for the Software may not be shared or used concurrently on different computers.
2. Transfer. You may permanently transfer all of your rights under this License Agreement according to the following provisions: (a) you transfer the entire Software Product, including all component parts, media, printed materials, any upgrades, and this License Agreement; (b) the recipient agrees to the terms of this License Agreement; (c) you do not retain any copies of the Software Product or any component parts, including any upgrades received for the Software Product; (d) the Software Product is not labeled "Not for Resale" or "Demonstration Copy".
3. Demonstration Copies. You may not resell or otherwise transfer the Software Product if it is labeled "Not for Resale" or "Demonstration Copy".
4. Components. The Software Product is licensed as a single product, and its component parts may not be separated for transfer or for use on more than one computer.
5. Rental or Lease. You may not rent, lease, or lend the Software Product.
6. Reverse Engineering. You may not reverse engineer, de-compile or disassemble the Software Product.
7. Termination. Without prejudice to any other rights, Dostek may terminate this License Agreement if (a) you fail to comply with the terms and conditions of this License Agreement, or (b) you fail to comply with

the terms of the Sales Invoice or Agreement of Sale for the Software Product as issued by Dostek Incorporated or by an authorized Dostek re-seller. On termination of this License Agreement by either party, you must destroy all copies of the Software Product and all of its component parts in your possession.

7. Temporary License. If you are granted a Temporary License that is valid only until a specified Termination Date, this License Agreement automatically expires on the specified Termination Date. On termination of the Temporary License, you must comply with the conditions of Termination (paragraph 6), or obtain a License Renewal from Dostek.

8. Upgrades. To qualify for a specially-priced Software Product Upgrade, you must be properly licensed. Use of the upgraded Software Product is subject to the terms of this License Agreement and the License Agreement (if any) provided with the upgrade.

9. This License Agreement is governed by the laws of the Province of Ontario, Canada.

LIMITED WARRANTY

Dostek warrants that the Software Product will perform substantially in accordance with the accompanying documentation for a period of ninety (90) days from the date of receipt. Dostek will make every reasonable effort to correct any problem issues. This Limited Warranty is void if failure of the Software Product results from abuse, improper application or accident.

LIMITATION OF LIABILITY

Reasonable care has been taken in the design and preparation of the Software Product. To the maximum extent permitted by law, in no event shall Dostek Incorporated be liable for any indirect, special, incidental or consequential damages whatsoever (including, without limitation, damages for loss of business information, business interruption, business profits, or any other loss) in connection with or resulting from the use or the inability to use the Software Product. Dostek's entire liability under any provision of this License Agreement shall be limited to the amount actually paid by you for the Software Product.

NO OTHER WARRANTIES

Dostek Incorporated disclaims all other warranties and conditions, either express or implied, including, but not limited to, implied warranties of merchantability and fitness for a particular purpose.

Please contact Dostek Incorporated if you have any questions concerning this License Agreement.

Dostek Incorporated
238 Westheights Drive
Kitchener, Ontario
Canada N2N 1J9

www.dostek.com

Dostek DNC

Getting Started

Thank you for choosing Dostek DNC. This guide provides an overview of Dostek DNC and explains how to install and configure the software, use the documentation and obtain technical support.

1. Installation	1
2. Software License	4
3. Documentation	4
4. Software Overview	5
5. Using Dostek DNC	8
6. Software Configuration	9
7. Organizing Data	10
8. Data Backup and Protection	11
9. Technical Support	13

1 Installation



Before installing Dostek DNC, please close all other applications. If you are installing Dostek DNC on a Windows NT, 2000 or XP system, please log on to an administrator account.

The installation process includes both the software installation itself plus completion of the Dostek DNC First-Time Setup Wizard. The Wizard starts automatically when software installation is complete, and guides you through the process of configuring and preparing the software for your use.

If you are installing Dostek DNC for the first time and are not using a computer network, skip ahead to section 1.1, "Start Master Setup".

Replacing an Existing Installation

Dostek DNC may be reinstalled without "uninstalling" first. Dostek DNC Setup never replaces or erases existing configuration files, and replaces other files only if the file being installed is newer than the existing file.

If you are reinstalling Dostek DNC because you suspect a file is corrupt, follow this procedure:

1. Make a backup copy of all files in the "C:\Dostek DNC\Settings" folder.
2. Uninstall Dostek DNC using "Install/Remove Programs" in the Windows Control Panel.
3. Erase the "C:\Dostek DNC" folder and sub-folders.
4. Install Dostek DNC.
5. Restore the files saved in step 1 above to the "C:\Dostek DNC\Settings" folder.

Using Dostek DNC on a Network

Dostek DNC includes many features that simplify operation in a network environment, including File Manager support for multiple root folders and network file archiving, and a Configuration Manager wizard to simplify backup and management of computer configuration profiles to a file server.

A separate copy of Dostek DNC is normally installed on each computer. If you need to use Dostek DNC with terminal server computers (that is, to run a single copy from a file server), contact Dostek for assistance.

To simplify installation on multiple computers, Dostek DNC may be installed over a computer network using the following procedure:

1. Create a new folder named D32SETUP on the network file server.
2. Using Windows Explorer, select all files and folders in the root directory of the Dostek DNC CD-ROM, and drag or copy the files to the new D32SETUP folder.
3. To install Dostek DNC on any computer on the network, click the Windows Start button, choose Run, and specify the "D32SETUP\Setup.exe" file on the network drive. Specify by typing the full path or by clicking Browse to search.

1.1 Start Master Setup

Dostek DNC may be downloaded from the Dostek web site or may be installed from a software CD, diskettes or a network file server. Start Dostek DNC Master Setup using one of the methods listed below, click the "Start" button and follow the on-screen instructions. When Setup is finished copying files, you may be asked to reboot the computer to complete the installation.

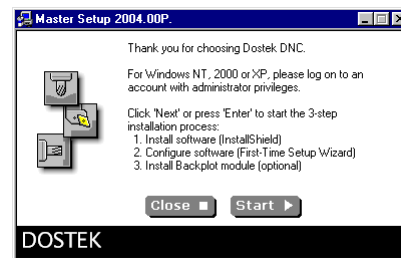

Install from CD

Insert the CD in your computer's CD drive. The Windows "Auto-Run" feature should automatically start the Dostek DNC Master Setup program within a few seconds. Or, you can start the Setup program manually as follows —

- click the Windows Start button, then click Run, then click Browse
- select the CD drive and choose file `SETUP.EXE`
- click Open, then OK

Install from Download

Dostek DNC may be installed by downloading from the Dostek web site (www.dostek.com). Choose "Dostek DNC" under the "Dostek DNC Full Installation" heading on the "Downloads" page. After entering your web site username and password (printed on a label on the inside front cover of this manual), select a download option:

- A. "Run this program from current location". This option provides a one-step installation.
- B. "Save this program to disk". This option provides a two-step installation. A copy of the Dostek DNC download file is stored on your computer in the folder you specify. After the download is complete, open the downloaded file to complete the installation. Choose this option if you wish to install Dostek DNC on more than one computer.

Install From a Network File Server

To install Dostek DNC from a network file server, click Start, choose Run, and specify the Dostek DNC "`SETUP.EXE`" file by typing the full path or by clicking Browse to search. See "Using Dostek DNC on a Network" above for more information.

1.2 First-Time Setup Wizard

The Dostek DNC First-Time Setup Wizard starts automatically when software installation is complete, or the first time you start Dostek DNC. The Wizard introduces you to the features of the Dostek DNC software and guides you through the initial setup process, including installation of your software license key, specifying the location of your CNC program files, connecting CNCs to the computer, configuring and testing CNC communication, and backing up your configuration settings. Taking a few minutes to carefully complete the Setup Wizard will save you time and help you use Dostek DNC more effectively.

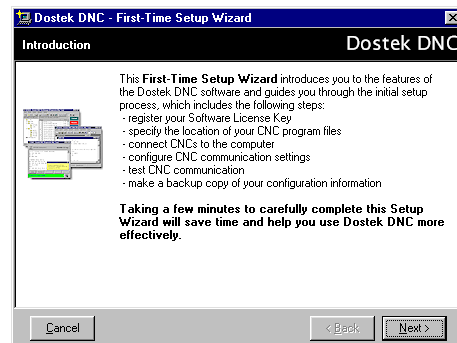

Dostek DNC Navigator

When the First-Time Setup Wizard finishes, it automatically starts the Dostek DNC Navigator (please refer to *Section 4.1 Software Components* for more information).

1.3 Removing Dostek DNC

To remove Dostek DNC from your computer, follow this procedure:

1. Start Windows Control Panel, choose "Install/Remove Programs" and select Dostek DNC from the list of installed software.
2. For your protection, Dostek DNC Uninstall does not erase any of your configuration files. To fully remove Dostek DNC, you must erase the "Dostek DNC" folder using Windows "My Computer" or Windows "Explorer".

2 Software License



Dostek DNC requires a simple license key to enable software operation (a hardware lock or other copy protection is not used). If Dostek DNC is not licensed (or your temporary trial license expires), all software features work, but the "About Dostek DNC" form appears periodically to remind you that the software is unlicensed.

If you purchased Dostek DNC directly from Dostek, your license key is recorded on the CD and will be installed automatically when you install the software. If you purchased Dostek DNC from a dealer and the package includes a registration form, you must register with Dostek to obtain your permanent software license key.

3 Documentation



A printed copy of the Dostek DNC manuals is provided with the purchase of a master software license. Additional copies may be ordered from Dostek. An "online" ("electronic") copy of the manuals is installed on your computer when you install Dostek DNC. The online documentation requires Acrobat Reader software. If the Acrobat Reader software is not already installed on your computer, you may install it from the Dostek DNC software CD or download it free from www.adobe.com.

When viewing documents on your computer using Acrobat Reader, you may view a table of contents, print all or part of the document, search for text and zoom in to view detail. Following is a list of some useful Acrobat Reader commands:

Function	Acrobat Reader Command
View Table of Contents	Window> Show Bookmarks
Jump to Section	Click Heading in Bookmarks
Print Pages	File> Print
Search	Edit> Find
Zoom	View> Zoom... or View> Fit...

To view the online documents, click Windows Start>, Programs>, Dostek DNC> and choose a document. Alternately, choose the Help menu in a Dostek DNC application and pick User Guide or Configuration Guide.

4 Software Overview



Dostek DNC is available in four "Editions". Lite Edition and Professional Edition are suitable for applications where the operator initiates file transfers at the computer. Multi-Port Edition provides remote upload and download to allow the CNC operator to initiate file transfers at the CNC (without touching the computer). BTR Edition is included free with purchase of a Dostek BTR (and communicates only with a Dostek BTR).

Professional Edition

Dostek DNC Professional Edition includes an explorer-style file manager, program editor with side-by-side file comparison and a DNC communication application. You can connect all your CNCs to one computer, or you can connect each CNC or workgroup (group of CNCs) to separate computers. One computer can easily drip feed to 4 or more CNCs at a time if needed.

Lite Edition

Dostek DNC Lite Edition is similar to Professional Edition, but is only able to communicate with one CNC at a time and does not include side-by-side file comparison and some of the file searching abilities of Professional Edition.

MultiPort Edition

Dostek DNC MultiPort Edition includes all features of the Professional Edition, with the addition of a MultiPort DNC Server application. A single computer can serve all CNCs, or you can split the load among multiple computers to serve a large number of CNCs.

Each CNC must be connected to a separate computer communication port, since all CNCs can communicate simultaneously.

The CNC operator sends commands to the DNC server computer by punching a small command file. To download a file, the CNC operator would create a command file (or edit an existing command file), punch the file, wait a few seconds and execute a read command. For example, to request file "A7-53759", the CNC operator could punch the file:

```
O7990  
(SEND A7-53759)  
%
```

This simple method works with most CNCs, and does not require the purchase of a special DNC option for the CNC.

4.1 Software Components

Dostek DNC Professional Edition (Order number 10-5000) includes the following components:

DDNAV	Dostek DNC Navigator
DDFM32	Dostek DNC File Manager
DEdit32	Dostek DNC Editor
DDNC32	Dostek DNC Communication
DConfig	Dostek DNC Configuration
DBasicUI	Dostek DNC Basic User Interface
Utilities	Terminal, Filter, Rename, etc.

Dostek DNC MultiPort Edition (10-5500) includes all of the Professional Edition components plus the following additional components:

DMComm	Dostek MultiPort DNC Communication Service
DMDNC32	Dostek MultiPort DNC Server

Dostek DNC Standard Edition, which includes only the Dostek DNC Communication and Configuration applications, is available for OEM applications or by special order.

Navigator - DDNAV



Dostek DNC Navigator is like a 'Control Panel' for Dostek DNC. It provides categorized links to all Dostek DNC applications, documents and help files to let you quickly find the function or information you need.

Initially, Dostek DNC Navigator starts automatically each time Windows starts. You may disable automatic startup by clearing the check box on the Navigator form. Navigator may be restarted using Windows Start, All Programs menu or by choosing 'Navigator' from the 'Help' menu in many of the other Dostek DNC applications.

File Manager - DDFM32



Dostek DNC File Manager is similar in appearance and function to the familiar Windows Explorer, with additional features to simplify NC program management:

- pick a file and click a menu, icon or "QuickButton" to launch Dostek DNC Editor or Communication applications
- create, copy, edit, view, rename, delete, and print files
- search for files by name or by file content
- restrict access to specific folders and file types
- restrict use of commands that access or modify files
- provide shortcuts to commands or applications using configurable "QuickButtons"
- group multiple program files together to form "jobs"
- view documents related to a CNC program file, such as CAD drawings or setup sheets

Configuration - DConfig



The Dostek DNC Configuration program configures software options and communication parameters, and includes a Configuration Manager to save and load configuration files as well as a Shortcut Manager to set up Windows menu and desktop shortcuts.

Communication - DDNC32

The Dostek DNC Communication application transfers files between the computer and CNC machine tools. Features include:

- start or restart transmit from any place in the file
- group multiple files together as a single “job”
- automatically store received programs according to the program name or part number
- automatically select a machine configuration according to the current file folder

To transmit or receive files, choose Transmit or Receive from the File Manager or Editor menus, click a Windows Desktop or Start Menu shortcut, or drag one or more files from another application and drop them on the `DDNC32` desktop icon.

Editor - DEdit32

Dostek DNC Editor features include:

- edit multiple files of virtually unlimited size
- compare files side-by-side
- search for and replace text
- cut and paste text between files
- reformat programs (renumber, expand, compress, filter, etc.)

To edit files, choose Edit from the File Manager or Communication menus, click a desktop or Windows Desktop or Start Menu shortcut, or drag one or more files from another application and drop them on the open Editor window or on the Editor desktop icon.

MultliPort DNC - DMDNC32 / DMComm

The Dostek MultliPort DNC Communication Service handles simultaneous communication sessions between the computer and multiple CNCs. It operates as a background task and may be started automatically as a Windows service (without a user login).

The Dostek MultliPort DNC Server application provides a user interface for monitoring and controlling the `DMComm` Communication Server. `DMDNC32` displays a table of active DNC channels and permits the user to monitor remote operations, assign devices, transmit files, manage queues, and so on. When started, `DMDNC32` automatically loads `DMComm`(if `DMComm` is not already running as a Windows service).

Utility Programs

The following utility programs are provided to assist with communication troubleshooting and file conversion.

- `DTerm32` Communication terminal program for testing communication and troubleshooting problems.
Refer to *Configuration Guide*, Section 5.3.
- `DFilter` Reformat CNC programs (remove lines, comments, block numbers, spaces, blank lines and unprintable characters; replace text; convert end of line codes; convert to upper case).
Refer to Application Note AN05 - *Using DFilter to Modify Files*.
- `DRename` Rename groups of CNC programs or change file type. Refer to Application Note AN06 - *Using DRename to Rename Files*.

5 Using Dostek DNC



To start a Dostek DNC application program, click the Windows Start button, then choose Programs> Dostek DNC> and choose an application from the sub-menu. Dostek DNC File Manager is normally started first because it provides an easy way to find files and quickly launch the other applications (transmit and receive, edit, configure).

Shortcuts

Shortcuts may be created in the Windows Start Menu, Programs Menu, Favorites Menu or the Windows Desktop by starting the Dostek DNC Configuration application and choosing Tool> Shortcut Manager.

Multiple Tasks

All Dostek DNC applications may be opened simultaneously. Use the Windows Task Bar or [Alt][Tab] command to switch from one to another. Only one instance each of the Dostek DNC File Manager, Editor or Configuration applications may be started. Multiple instances of the Communication application may be started, but each instance must use a different communication port.

Tooltip Help

A brief description of each control (toolbar button, command button, check box) and data entry field (list, text box, etc.) is provided as 'tooltip' help that appears when you hover the mouse pointer over the item.

6 Software Configuration



Although you can start using Dostek DNC right away, many configuration options are provided to allow customization to suit your preferences. Following is a list of some features you may wish to configure as you become familiar with Dostek DNC.

- Display
 - specify startup folders
- Preferences
 - list only files of specific types
 - specify toolbar size and style
 - specify File Manager text size
 - specify Editor font, size, color and background color
- Convenience
 - access internal and external commands with File Manager Utility menu or QuickButton shortcuts
 - enable/disable drag-and-drop file copying
- Security
 - require password to modify files, manage folders, change preferences, etc.
 - limit access to specific folders and file types
- Communication
 - format and filter data sent to CNC machines
 - specify text font and size
 - automatically name received files
 - automatically select device configuration according to file location
 - automatically trigger communication when CNC is ready
 - assign an icon to each device (CNC)
 - display operator instructions or messages when sending or receiving

For more information about software configuration refer to:

- "File Manager Options", *User Guide*, Section 3.10
- "Editor Preferences", *User Guide*, Section 4.1
- "Configure Application Options", *Configuration Guide*, Section 3
- "Configure Device Parameters", *Configuration Guide*, Section 4

A detailed installation and configuration checklist is provided on the first page of the *Configuration Guide*.

6.1 Device Configuration Samples

Sample device configuration files are provided for a variety of CNCs. To use a sample file, start the Dostek DNC Configuration application and choose "Import Sample Configuration" from the File menu. Refer to "Configure Device Parameters", *Configuration Guide*, Section 4 for more information.

6.2 Connect CNCs and Test Communication

Dostek DNC works with standard COM ports, multiport serial cards, Ethernet/serial hubs and wireless ports. A computer's standard COM port is usually a 9-pin "D-subminiature" type connector located on the back panel.

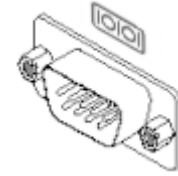

Refer to *Configuration Guide* Section 5, "Device Wiring and Testing", for suggested cable wiring.

Considerable startup time can be saved by following the simple test procedure provided in *Configuration Guide* Section 5.2. Always test communication by first sending a program from the CNC to the computer. The reason is as follows. If the communication settings are incorrect, many CNCs provide ambiguous or misleading alarm messages and display no received data. Dostek DNC, especially the Dostek DNC Terminal utility, usually display data even if errors are detected and provide a more detailed and accurate error indication.

If you experience a communication problem that is not covered by the tips and test procedure provided in the *Configuration Guide*, contact Dostek technical support for assistance (Section 7).

6.3 MultiPort DNC Server

The Dostek MultiPort DNC Server application provides remote call-up of programs directly from the CNC. Because this is an automated process, a specific protocol must be followed. Although there is considerable flexibility in the protocol, the device configuration must be completely set up and tested for the process to work properly. Refer to the *Multi-Port Supplement* for more information.

7 Organizing Data

Dostek DNC can access files stored on the computer's hard drive or on a network file server. Files can be organized in sub-folders by criteria such as CNC machine type, product type or customer. Consider the following factors when organizing file storage:

- Files are usually easier to manage (backup, restrict access, etc.) when they are all organized under a common folder such as in the example at right ("F:\NC").
- Organizing files by machine type makes it possible to restrict or automate device selection (*Configuration Guide*, Section 3.4.1).
- Storing a large number of files in a folder will adversely affect performance (it will take longer to open a folder or search for information).
- Files on a network file server can be accessed by mapping a network folder to a drive letter or by specifying the UNC path specification; the UNC name is comprised of two backslash characters followed by the server name, another backslash, then the path and file specification (for example, "\\Server1\Path\Filename").
- The Windows Recycle Bin does not protect files accessed over a network connection — take precautions to ensure your file server is properly equipped and configured to protect your data.

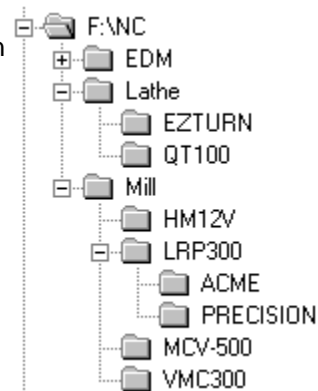

8 Data Backup and Protection - Planning for Disaster

What if your computer is stolen or stops working? What if your files are erased accidentally? What if your plant falls victim to a natural disaster? Are you prepared?

Here are some steps you could take to protect your investment:

- Regularly make a backup copy of all of your CNC program files (see *Data Backup* below) and your Dostek DNC configuration files (see *Configuration Backup* below).
- Store a copy of your data in a secure environment-proof vault.
- Store a copy of your data off site in a secure location.
- Store your Dostek DNC printed manual, software CD and configuration data in a secure location.
- Make a duplicate copy of your Dostek DNC software CD and configuration data, and store the copy off site.
- Copy the content of your Dostek DNC software CD and configuration data to your enterprise file server where it will be protected by your enterprise backup system.

8.1 Data Protection

Dostek DNC provides several security features (*Configuration Guide*, Section 2.1) to restrict how users may access, modify, create and delete files.

If you allow users to save CNC programs from the CNC to the computer, Dostek DNC provides features that may be used to prevent overwriting of your original files. When receiving from the CNC, the Dostek DNC Communication application replaces existing files with the same name as received files (*User Guide*, Section 5.3.1). To prevent received files from replacing original files, use one or more of the following techniques:

- Configure Dostek DNC to add a prefix, suffix or special file extension to automatically named received files.
- Configure Dostek DNC to store received files in a separate folder.
- Configure Dostek DNC to require the Supervisor password to use the Receive command.
- Protect original files by setting file attributes to "Read Only".
- If files are stored on a network file server, set the share privilege to "Read Only".

Files on the computer's local disk drives that are deleted by the operator or replaced by received files may be protected by the Windows Recycle Bin, if it is enabled. However, the Recycle Bin does not protect files accessed over a network.

8.2 Data Backup

To protect your data files, make regular backup copies using a tape backup system or removable disk media.

Typical backup schemes use a set of media for revolving backups. For example, a set of five tapes is used for daily backups, and a set of four additional tapes is used for weekly backups. Revolving backups may not protect data files under certain circumstances:

- A new file is accidentally erased before the daily backup occurs.
- An existing file was accidentally deleted, but went unnoticed for six weeks; the oldest revolving backup tape is only a month old.
- If files are restored from a backup, files that were recently deleted intentionally will now reappear.

For maximum data protection, consider the following:

- Make a permanent backup copy monthly, and store permanent copies off-site.
- Keep a second copy of data files on another computer, and update the copy daily, weekly or monthly as required.
- Keep records when creating, modifying or removing files.
- Implement a backup system that is easy to use and can be highly automated. A backup system that is difficult to use likely will not provide adequate protection.
- Prepare a backup computer system that can be quickly installed to replace your working system. If your system includes add-on communication products (multi-port serial boards, Ethernet/Serial hubs, etc.), prepare any cables necessary to allow your backup computer to bypass the add-on products and connect directly to each CNC. Test your backup computer with each CNC to make sure it works. Your Dostek DNC software license permits you to install a copy of your Dostek DNC software on a backup computer.
- Prepare a written disaster recovery plan, review your plan, and test your backup computer at least once each year.

8.3 Configuration Backup

Setting up communication with CNCs is often difficult and time consuming because of a lack of standards and quirky design. Consider the effort it might take to start again from scratch if you lose your Dostek DNC configuration information or your CNC parameter data.

Therefore, it is extremely important that you:

- Make a backup copy of your Dostek DNC configuration files.
- Record the setting of communication-related parameter settings for each CNC.

The Dostek DNC Configuration Manager (*Configuration Guide*, Section 3.6) makes it very easy to back up your Dostek DNC configuration information. You can back up the data to a removable media (diskette, USB memory stick, etc.) or to a network folder.

If you would like to add the Dostek DNC configuration data to your regular backup system, add folder "C:\Dostek DNC\Settings".

To record the setting of the CNC communication parameters, consider the following:

- Find the communication parameter pages in the CNC manual, and write your current settings next to each parameter description.
- The Dostek DNC Configuration application provides a 'Notes' tab that allows you to record any notes about parameter settings, wiring, reminders or observations for each CNC configuration. When you record information here, it is automatically backup up when you save your Dostek DNC configuration data, and is readily available right for immediate reference right on the computer.
- If your CNC permits, punch out all parameters to a file on the computer (using Dostek DNC's Receive command). Name the file according to the date the parameters are saved. If you ever suspect that a parameter has changed, you can save a new copy of the parameters on the computer, and use the Dostek DNC side-by-side file comparison feature (Professional, MultiPort Editions) to quickly determine if there are any differences.

Also, please remember to:

- Make a new backup copy of your Dostek DNC configuration files each time you make a configuration change.
- Make a duplicate copy of your configuration data and parameter settings for off-site storage.

9 Technical Support



Telephone technical support (toll free in USA and Canada) is free for a specific time period after you purchase the Dostek DNC software, and is thereafter available by annual subscription. Free technical support is always available by email (see below).

Dostek welcomes your phone calls. However, **PLEASE BE PREPARED TO PROVIDE SPECIFIC INFORMATION ABOUT YOUR PROBLEM.**

Following are some suggestions and guidelines for the questions you should be prepared to answer.

9.1 Installation Problem

If you experience difficulty installing Dostek DNC:

- If an error message is displayed during installation, please write it down, print it, or save a screen image to a document file. To save the screen image, press the PtrScrn button on your computer keyboard, then open your word processor or the Paint program (Start, All Programs, Accessories, Paint) and choose Edit, Paste. To print the screen image, first save it as described and choose File, Print from the word processor or Paint menu.
- If you are using Windows NT, 2000 or XP or are installing the software on a network file server, be sure to use an account with administrator privileges.
- Before installing Dostek DNC, ensure that all other Windows applications are closed.
- Follow the installation instructions provided in this manual and on the computer screen carefully.
- Be sure to complete the Dostek DNC First-Time Setup Wizard which starts automatically when you install the software.
- Refer to the 'Installation Problems' help file on the Dostek web site technical support page (www.dostek.com/support.htm).
- Try installing Dostek DNC on a different computer, especially if your computer is old or has exhibited other problems. Windows computers can become unstable over time due to viruses, spyware, registry problems, installation of non-compliant applications, and so on.

9.2 Computer Problems

If you experience difficulty starting the Dostek DNC software or performing a specific task:

- If the computer displays an error message, please write it down, print it, or save a screen image to a document file. To save or print the screen image, refer to the first list item in Section 9.1 above.
- Close all open windows, restart the Dostek DNC software and attempt the operation again to ensure the computer has sufficient memory and resources available to complete the task.
- Ensure the computer's disk drive is not full.
- If you are attempting to access files on a network resource, ensure that the network is working properly and that you have sufficient network privileges to access the resource.
- Turn the computer off, wait a few seconds, then restart the computer and attempt the operation again.

9.3 CNC Communication Problems

If you experience difficulty transferring data between the computer and CNC machines:

- Try using the sample device configuration, if any, provided for your CNC. Start the Dostek DNC Configuration application and choose 'File', 'Import Sample Configuration' from the menu. Click the Notes tab and follow the provided instructions, if any.
- Keep notes. Before you change any CNC parameters or Dostek DNC configuration settings, write down the current setting, the new setting, and the reason for the change.
- If the CNC or the computer display an alarm code or error message, please write it down. In the case of a CNC alarm code, please find the alarm description in the CNC manual and write it down or make a photocopy of the manual page.
- Read Section 5.2, Testing Communication, in the *Dostek DNC Configuration Guide* for detailed test procedures.
- View the *Communication Testing and Troubleshooting* help file (Navigator Help tab, or Dostek DNC Help menu) for detailed recommendations for typical communication problems. Go to the 'Problem Topics' section and find the topic heading that most closely describes your problem.
- Please write down exactly what you were attempting to do when the problem occurred, including the commands or key sequences you pressed.

9.4 Submit Configuration and Data Files

To diagnose your problem, Dostek may require a copy of your Dostek DNC configuration files and/or a copy of one of your CNC part programs. You may submit files to Dostek by email.

To submit your Dostek DNC configuration files by email:

- Start the Dostek DNC Configuration application.
- Choose 'File', 'Explore Folder', 'Dostek DNC Settings' from the menu. This opens a Windows Explorer view of the Dostek DNC 'Settings' folder.
- Choose 'Edit', 'Select All' from the menu to select all files.
- Choose 'File', 'Send To', 'Mail Recipient' to attach the files to an email message, and specify 'support@dostek.com' in the 'To' field.
(If the computer does not have an email application installed, copy the files to another computer that does have an email application. For example, choose 'File', 'Send To', 'Floppy' to copy the files to a blank diskette.)

9.5 Support Guidelines

Dostek technical support is intended to help you with initial installation and configuration of your system, including configuration of communication parameters on your CNC machines, and resolution of occasional problems that may arise. In order to provide quality technical support at reasonable cost, there are some limitations and exclusions, including:

- When describing a problem, be specific and avoid the use of slang and ambiguous terminology. For example, instead of saying "When I'm downloading the CNC crashes and the computer freezes", say "When I'm sending a file from the computer to the CNC, the CNC indicates alarm 86 and the Dostek DNC software stops after sending 14 percent of the file and displays 'XOff char received'".
- If your computer fails or is lost or stolen, Dostek technical support is intended to help you re-install your Dostek software and restore the Dostek DNC configuration files from your backup copy. If you fail to make a backup copy, or lose your copy, Dostek technical support will help you reconfigure your system from scratch at your expense.
- Dostek technical support is not intended to teach you how to use your computer or your CNC machine. Training is available from Dostek at reasonable cost. If you are not proficient with your computer and require support, consider arranging with your local computer services provider to prepare your computer for remote control using Windows Net Meeting or Remote Desktop so a Dostek support technician can log on to your computer and perform tests or make configuration changes.
- If you purchase third-party products (such as serial boards or hubs) from Dostek, you may need to contact the product manufacturer for technical support and repairs.

9.6 Contact Dostek

Before contacting Dostek, please review the recommendations in Sections 9.1 through 9.4, and have your notes ready (observations, error messages, alarm codes, measures you have taken, and results of tests you have conducted, etc.).

Accurate and complete information will result in the fastest possible resolution to your problem.

Whether you contact Dostek by telephone, fax or email, be sure to provide your complete contact information including all of the following:

- Your full name.
- Your company name. (Required to locate your file)
- Your telephone number, including area code. (Even if you contact Dostek by fax or email, it may be necessary to contact you by telephone)
- Your correct email address (Even if you contact Dostek by telephone or fax, it may be necessary to send you information by email)
- The software version number of your Dostek DNC software (Navigator 'About' tab, or choose 'Help', 'About' from menu.
- A concise description of the problem you are experiencing.

Email support@dostek.com

Telephone 888-355-5735 (Toll free, USA and Canada)
519-742-5721
8am - 5pm EST, Monday to Friday

Facsimile 519-741-8669

Internet www.dostek.com/support.htm

Notes
